

## 1. Preparation of the MMC/SD memory card.

On a blank card, copy the mp3 files containing the audio tracks. For best quality, the audio files should be recorded with a sampling rate of 44khz (CD quality) mono or stereo. They are then encoded in mp3 at a rate chosen by the user from 32 to 256 kbits/s.

The files must be copied into the root folder of memory card, do not create folders.

The maximum number of files is 250.

The maximum size for a single file is 32 MBytes.

The files will be played in the same order that they were copied to the memory card, ie. the first file to be copied will be triggered by switch 1. For this reason, avoid copying all the files at a time, but proceed one by one. Be aware that windows explorer generally display files in alphabetic order. To view the real order you should sort your display by creation time.

Check your files by playing them on the PC directly from memory card.

Do not withdraw the card of its reader before the copy is fully completed, with a right click on the icon representing the card reader, choose "eject".

Be carefull not to add hidden or sytem files on the memory card. This is often the case with cards made with Apple MAC Os.

If you received a demo card, use it for the first test.

## 2. Memory card insertion and start.

With the power supply connector disconnected, introduce the card into the slot, label up (contacts down), and the side whose corner is cut towards the interior.

Connect an amplifier, active speaker or headphone into the audio plug (jack 3.5mm) which is in the center of the circuit. Take care of well inserting the audio jack in its connector. Do not use a mono connector, which should results in short-circuit of one output !

Check that jumper "on/off" is installed, or if an external switch is connected to the 2 pin header,check that this switch is open.

Place all switches "CONFIG" - except the switch 1 - on the position OFF.

Connect the power supply, and if it is used, close the external switch.

The LED must light on then off. After a short time, the first track must start, the LED flash during the reading.

## Important remarks concerning Power Supply.

Use a power supply with D.C. current in range 5V to 8V. Take care to never exceed this value. The required current is between 50 and 150 ma according to memory card used. A power of 1W is largely sufficient. Connection should be done by a jack such as those that equip the power adapters, in this case the positive must be in the center.

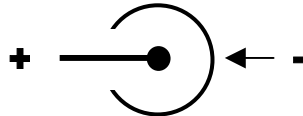

You may also use a 2 pins header marked “ + - “ on the side of the circuit close to the DC jack to power the board. Be careful to polarity.

## 3. Connection of trigger switches.

If the test is positive, you can now proceed to connect the starting contacts.

Pico-JukeBox has a screw terminal block with 6 entries, making it possible to connect up to 5 trigger switches. The switches must be connected at screws 1 to 5, the common return, same for the 5 contacts, is done on the leftmost connector, without number.

If you use only one contact, connect it to connector 1.

Any type of switch can be appropriate, it is possible to use any equipment, for example infra-red barrier or a pyroelectric sensor of presence, if it behaves like a passive momentary closing contact (with no potential).

Be aware that inputs are sensitive to electro static discharges and surges, so if you use long wires for triggers connections, use shielded cables. **Never connect or disconnect long wires with power supply on !**

## 4. Use of configuration dipswitches.

The following table describes the function of the configuration switches.

	OFF	ON
SW1	Stop	Autostart,Continue & Loop
SW2	Retrigger allowed	Retrigger forbidden
SW3	Keyb. Mode 1	Keyb. Mode 2
SW4	Loop on track 1 off	Loop on track 1 on

**SW1 :** **ON**, automatically start the reading on powering up, the reading starts with the first track and continue until the last track without interruption, to start again in loop with first track.

**OFF**, do not automatically start at power up, needs external trigger and stops at the end of the track.

**SW2 :** **ON**, it is necessary to listen to a track until the end before being able to listen to another. The keyboard is locked during the reading.

**OFF**, it is possible to start again a sequence or to pass to another during the reading.

**SW3 :** Choose contacts function.

**Mode 1 :** each contact start a track

<b>1</b>	<b>2</b>	<b>3</b>	<b>4</b>	<b>5</b>
<b>TRACK 1</b>	<b>TRACK 2</b>	<b>TRACK 3</b>	<b>TRACK 4</b>	<b>TRACK 5</b>

**Remark, it is not needed to use all 5 contacts.**

**Mode 2 :** the 5 contacts correspond to the following functions.

<b>1</b>	<b>2</b>	<b>3</b>	<b>4</b>	<b>5</b>
<b>NEXT</b>	<b>BACK</b>	<b>PAUSE</b>	<b>Vol -</b>	<b>Vol +</b>

When you use this mode to setup volume, the adjustment of volume is stored into flash memory.

**SW4 :** **ON**, in this mode, the picoJukeBox replays automatically track 1 at the end of any another track. The switch 1 (continue) must be also activated. (Example: background music)

**OFF**, no looping on track 1.

Other configuration functionalities are available with use of the serial interface (see « Serial Protocol » documentation). These adjustments are stored into flash memory.

## 5. Extension connector

The extension connector can be used to connect a matrix keyboard 4X3 or 4X4, this configuration excludes the use of the screw terminals contacts. Only the first 8 pins on the header are used for the keyboard.

1	C1	C3	L1	L3	
6	C2	C4	L2	L4	

In this case, the keyboard's columns have to be connected to pins 1-6-2-7, the lines to pins 3-8-4-9.

This configuration is only available for PicoJukeBox version 2 and above.

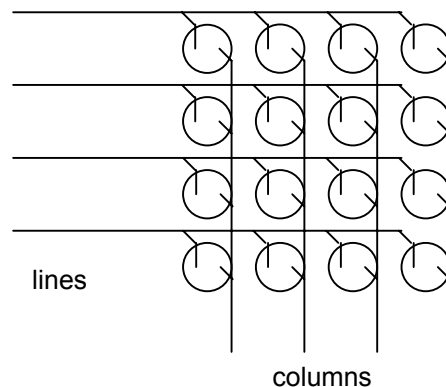

When a switch is closed, it establishes the connection between a line and a column

Pin 10 of the header is the ground, pin 5 is connected to the internal power 3.3V of the board. If an external circuit is connected and powered by this source, take care that the supply of this one does not exceed 50mA and it is not protected against short-circuit.

## 6. Use of the Serial interface

Pico-JukeBox has an asynchronous serial port. It can be connected directly to a microcontroller, it should however be noted that the signals are in logic 3.3V.

To connect the board to a PC, it is necessary to use a RS232 level adapter (like the max232). The interface should be configured to 9600 bauds, 8 data bits, no parity, 1 stop bit.

For a complete description of commands, please refer to PicoJB «Serial Protocol » documentation.

## 7. In case of trouble.

### LED do not light on.

Check power supply, positive-negative are correct?  
Is the jumper DC SW installed?

### LED lights on and flash but there is no sound.

Is audio plug correctly inserted?  
Is power amplifier switched on, with enough volume level?

### On starting, picoJB emits a long « beep » and led remains on.

Is there is a MMC/SD card?  
Is the card well inserted?  
Are there valid mp3 files on the card? (see 1 Preparation of the MMC/SD card)

## Technical specifications

Recording Format :	Digital mp3, 32->160kbs + vbr,
Sample frequency :	22khz and 44khz, mono and stereo.
Bandwith (-3db):	20 – 20khz
Output level (0db):	700 mv
Output impedance :	> 32 $\Omega$
Stereo isolation :	> 58db
S/N :	> 92db
Track access time :	< 100ms
Interfaces :	Serial port and logical levels
Audio connector :	jack stereo 3.5mm
Power supply connector :	jack DC and JSTHW
Configuration switches :	4
Processors :	2 (CPU RISC + DSP)
Recording media:	MMC cards or SD cards

## Recording duration :

MMC Card	Hq voice	+ music	CD quality
32MB	2 h	90 min	40 min
64MB	4 h	3 h	80 min
128MB	8 h	6 h	160 min
256MB	16 h	12 h	5h 30 min
512MB	32 h	24 h	11 h
1GB	64 h	48 h	22 h

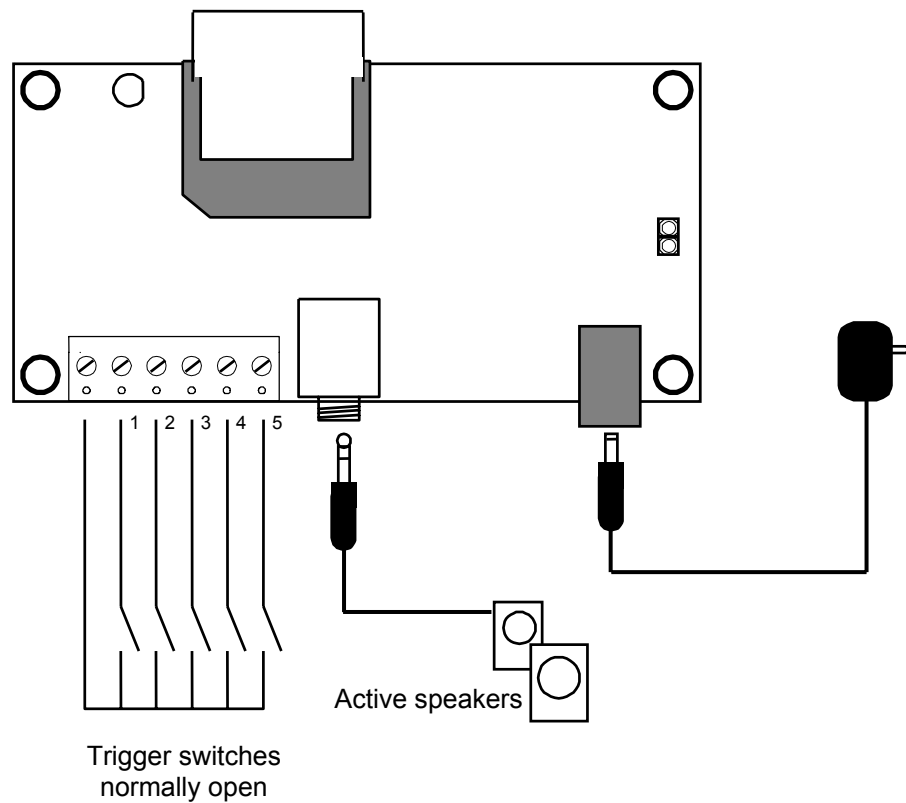
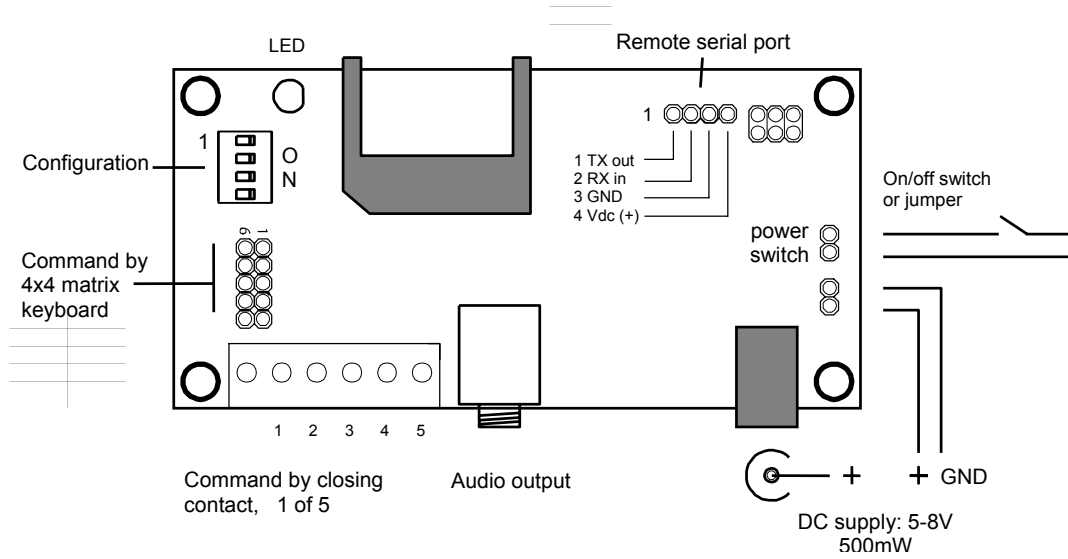

## Installation of the optional 16 keys matrix keyboard

The keyboard has an 8 ways cable attached to it.  
Connect the 10 pins header as shown on the picture.  
The 2 empty slots should be on pin 5 and 10.

The picoJukeBox will be instructed to run in matrix keyboard mode by putting a jumper on the serial connector between pins RX and GND.

When the board is powered up, the led should flash 5 times when this configuration is detected.

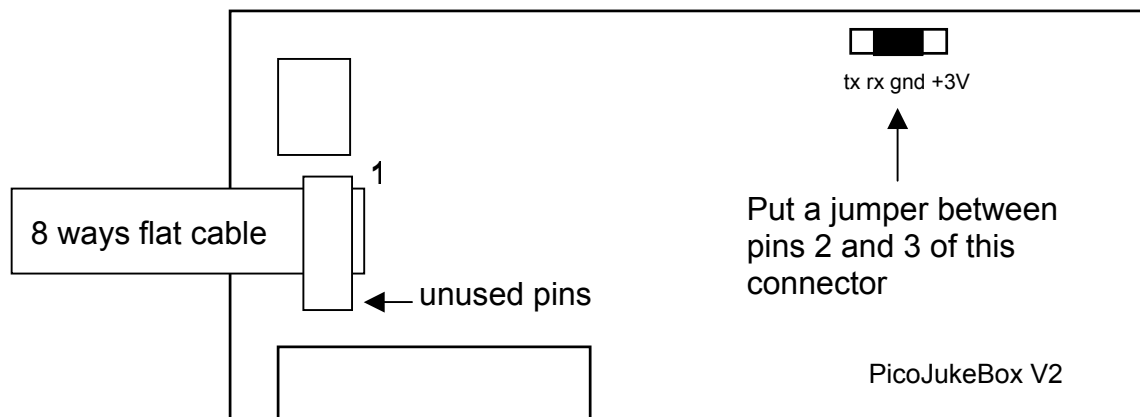

Do not connect wires to the screw terminal block when using matrix keyboard.